

Energizer[®] MAX.



Product Data Sheet / Fiche Produit

Short code : **EA70L3H**

General

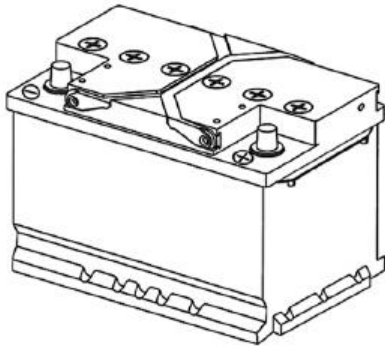

SAP #	679805
EAN #	4016987147009
Technology	AGM / VRLA
Alloy / Alliage	Ca / Ca
Maintenance	FREE
Origine	Europe
HS Code	85071020
Equivalent part	AGM-L3 / 570901
Label Short Code	EA70L3
Charge Eye	NO

Electrical Specifications

Voltage	12 V
Capacity (20 hrs)	70 Ah
Reserve Capacity <small>indicative</small>	130 Min
CCA (EN / SAE / IEC) @ -18°C	760 A

Transportation

Classified as :	AGM Battery
Batteries, wet, non-spillable, electrical storage	
UN number	UN 2800
Classification (ADR/RID)	Class 8
Packing Group (Not assigned for Land Transport)	Not Assigned

Dimensions / Mass

Max Length (L)	278 mm
Max Width (W)	175 mm
Max Height (H)	190 mm
Mass (Weight)	20,3 Kg

Container

Group Size	L3 AGM
Case Material	Polypropylène
Color	Black / Black
Venting	NO (VRLA)
Cover	T Cover / VRLA
Acid specific gravity	1,28
Bottom Hold Down	B13
Type of Terminal	EN / SAE (1)
Layout	0 (-/+)

Layout

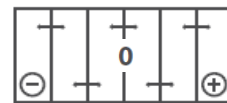

Terminal Type

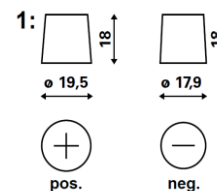

BASE Hold-Down

