

Energizer[®] MAX.



Product Data Sheet / Fiche Produit

Short code : **EP74L3H**

General

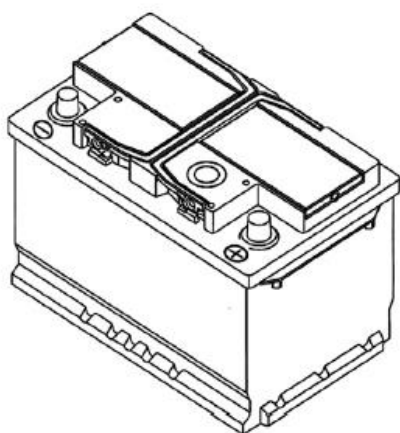

SAP #	679783
EAN #	4016987155646
Technology	Flooded / SLI
Alloy / Alliage	Ca / Ca
Maintenance	FREE
Origine	Europe
HS Code	85071020
Equivalent part	DIN74 - MF57412
Label Short Code	EP74L3
Charge Eye	Yes

Electrical Specifications

Voltage	12 V
Capacity (20 hrs)	74 Ah
Reserve Capacity <small>indicative</small>	135 Min
CCA (EN / SAE / IEC) @ -18°C	680 A

Transportation

Classified as : Flooded Battery
Batteries, wet, filled with Sulfuric Acid

UN number	UN 2794
Classification (ADR/RID)	Class 8
Packing Group (Not assigned for Land Transport)	III

Dimensions / Mass

Max Length (L)	278 mm
Max Width (W)	175 mm
Max Height (H)	190 mm
Mass (Weight)	17,89 Kg

Container

Group Size	L3
Case Material	Polypropylène
Color	Black / Black
Venting	Centralized
Cover	T Cover
Acid specific gravity	1,28
Bottom Hold Down	B13
Type of Terminal	EN / SAE (1)
Layout	0 (-/+)

Layout

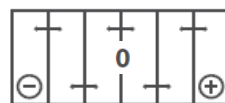

Terminal Type

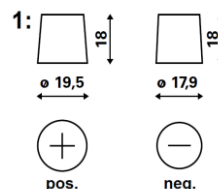

BASE Hold-Down

